



## P/N 8637.500

Motorized hose reel s. 637, for grease, 400 bar, without hose. Inlet-outlet G 1" (f)

### AREAS OF USE

Manufacturing industry, Mining industry, Shipping and offshore, Railway transport

### FEATURES

Pressure	400 bar
Compatible fluids	grease
Swivel joint	zinc plated steel
Seals	polyurethane
Characteristic	hydraulic
Material	painted steel
Couplings	-
Hose	-
∅ and hose length	-
Inlet	G 1" (f)
Outlet	G 1" (f)
Reel flow path	zinc plated steel



### OVERALL DIMENSIONS (mm)

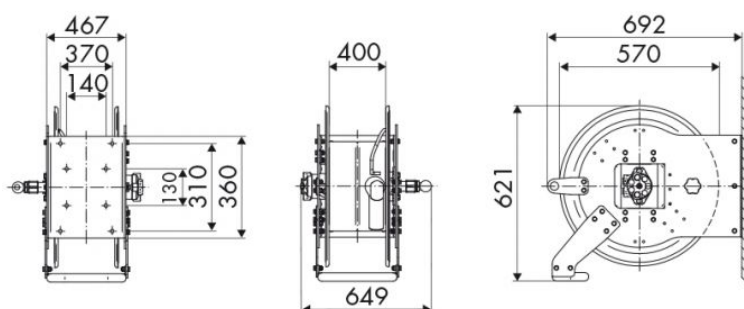

### HOSE REELS CAPACITY

∅ 3/8"	∅ 1/2"	∅ 5/8"	∅ 3/4"	∅ 1"
200 m	150 m	110 m	75 m	50 m