



P/N 8637.400

Motorized hose reel s. 637, for oil and similar, 150 bar, without hose. Inlet-outlet G 1" (f)

AREAS OF USE

Manufacturing industry, Mining industry, Shipping and offshore, Railway transport

FEATURES

Pressure	150 bar
Compatible fluids	oils and similar products
Swivel joint	zinc plated steel
Seals	polyurethane
Characteristic	hydraulic
Material	painted steel
Couplings	-
Hose	-
Ø and hose length	-
Inlet	G 1" (f)
Outlet	G 1" (f)
Reel flow path	zinc plated steel



OVERALL DIMENSIONS (mm)

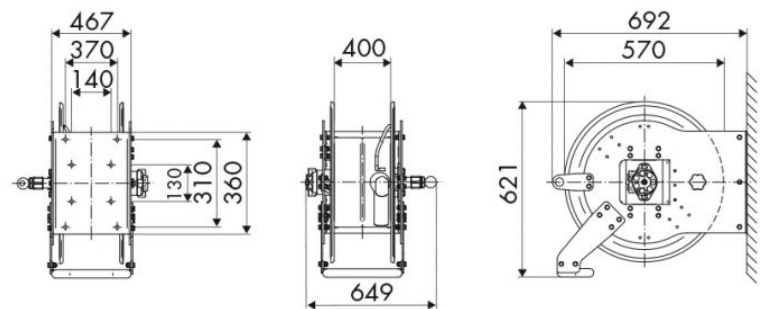

HOSE REELS CAPACITY

Ø 3/8"	Ø 1/2"	Ø 5/8"	Ø 3/4"	Ø 1"
200 m	150 m	110 m	75 m	50 m