



P/N 8637.100

Motorized hose reel s. 637, for air-water, 20 bar, without hose. Inlet-outlet G 1" (f)

AREAS OF USE

Manufacturing industry, Mining industry, Shipping and offshore, Railway transport

FEATURES

Pressure	20 bar
Compatible fluids	air - water
Swivel joint	brass
Seals	Viton®
Characteristic	hydraulic
Material	painted steel
Couplings	-
Hose	-
∅ and hose length	-
Inlet	G 1" (f)
Outlet	G 1" (f)
Reel flow path	brass - zinc plated steel



OVERALL DIMENSIONS (mm)

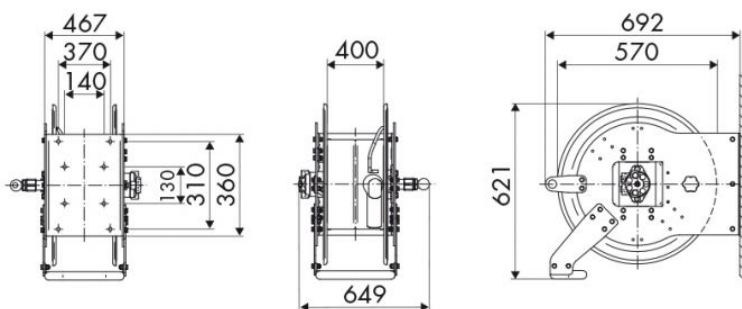

HOSE REELS CAPACITY

∅ 3/8"	∅ 1/2"	∅ 5/8"	∅ 3/4"	∅ 1"
200 m	150 m	110 m	75 m	50 m