



ADVANCED FLUID
MANAGEMENT SOLUTIONS

RAASM S.p.a.

Via Marangoni 33, 36022
S. Zeno di Cassola (VI) Italy
Tel. +39 0424 570891
info@raasm.com

P/N 7721301.100

Hose reel with electric motorization 24 V DC in painted steel s. 700, for water, oil, diesel and industrial fluids, 20 bar, without hose. Drum width 270 mm. Inlet-outlet G 2" (f)

AREAS OF USE

Manufacturing industry, Mining industry, Shipping and offshore, Railway transport

FEATURES

Pressure	20 bar
Compatible fluids	air - water - diesel fuel
Swivel joint	aluminum
Seals	Viton®
Characteristic	electric 24 V DC
Material	painted steel
Couplings	-
Hose	-
Ø and hose length	-
Inlet	G 2" (f)
Outlet	G 2" (f)
Reel flow path	aluminum - zinc plated steel



OVERALL DIMENSIONS (mm)

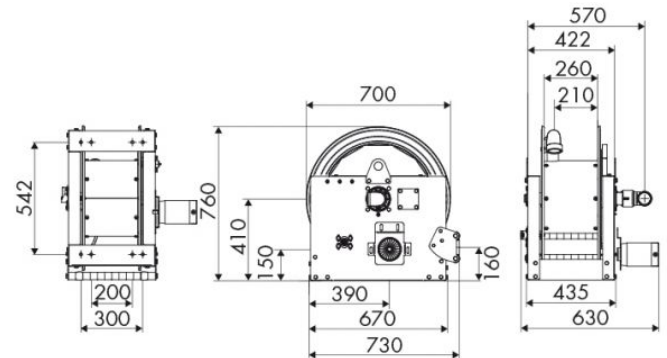

HOSE REELS CAPACITY

Ø 3/8"	Ø 1/2"	Ø 3/4"	Ø 1"	Ø 1,1/4"	Ø 1,1/2"	Ø 2"
160 m	110 m	65 m	32 m	20 m	17 m	10 m