



P/N 7725702.200



Hose reel with electric motorization 230 V AC - 50/60 Hz in AISI 316 stainless steel, ATEX s. 700, for water, oil, diesel and industrial fluids, 70 bar, without hose. Drum width 270 mm. Inlet-outlet G 2" (f) with rewinding clutch

AREAS OF USE

Manufacturing industry, Mining industry, Shipping and offshore, Railway transport

FEATURES

Pressure	70 bar
Compatible fluids	water - oils - diesel fuel - industrial fluid
Swivel joint	AISI 316 stainless steel
Seals	Viton®
Characteristic	electric 230 V AC - 50/60 Hz ATEX
Material	AISI 316 stainless steel
Couplings	-
Hose	-
Ø and hose length	-
Inlet	G 2" (f)
Outlet	G 2" (f)
Reel flow path	AISI 316 stainless steel



OVERALL DIMENSIONS (mm)

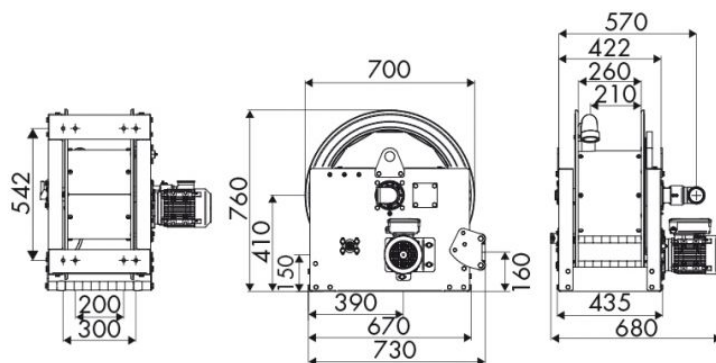

HOSE REELS CAPACITY

Ø 3/8"	Ø 1/2"	Ø 3/4"	Ø 1"	Ø 1,1/4"	Ø 1,1/2"	Ø 2"
160 m	110 m	65 m	30 m	20 m	15 m	10 m