



## P/N 7841001.3000



Manual hose reel s. 700, for oil and similar, 150 bar, without hose. Drum width 410 mm. Inlet-outlet G 1" (f)

### AREAS OF USE

Manufacturing industry, Mining industry, Shipping and offshore, Railway transport

### FEATURES

Pressure	150 bar
Compatible fluids	oils and similar products
Swivel joint	zinc plated steel
Seals	Viton®
Characteristic	manual
Material	painted steel
Couplings	-
Hose	-
∅ and hose length	-
Inlet	G 1" (f)
Outlet	G 1" (f)
Reel flow path	zinc plated steel

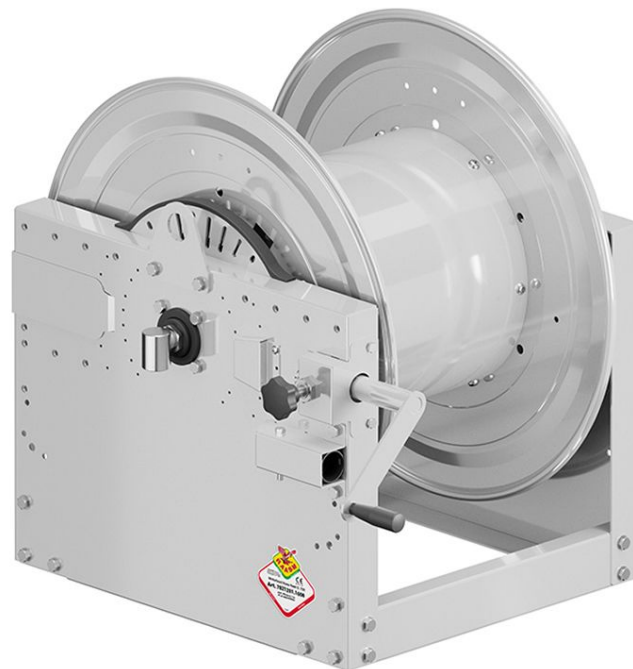

### OVERALL DIMENSIONS (mm)

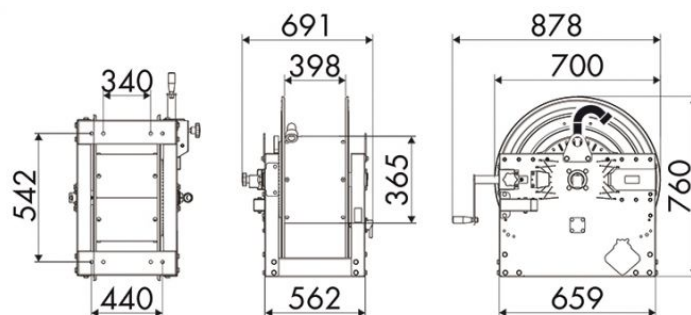

### HOSE REELS CAPACITY

∅ 3/8"	∅ 1/2"	∅ 3/4"	∅ 1"	∅ 1,1/4"	∅ 1,1/2"	∅ 2"
290 m	180 m	120 m	60 m	35 m	30 m	20 m