



## P/N 7821001.1000



Manual hose reel s. 700, for air-water and diesel, 20 bar, without hose. Drum width 270 mm. Inlet-outlet G 1" (f)

### AREAS OF USE

Manufacturing industry, Mining industry, Shipping and offshore, Railway transport

### FEATURES

Pressure	20 bar
Compatible fluids	air - water - diesel fuel
Swivel joint	aluminum
Seals	Viton®
Characteristic	manual
Material	painted steel
Couplings	-
Hose	-
∅ and hose length	-
Inlet	G 1" (f)
Outlet	G 1" (f)
Reel flow path	aluminum - zinc plated steel

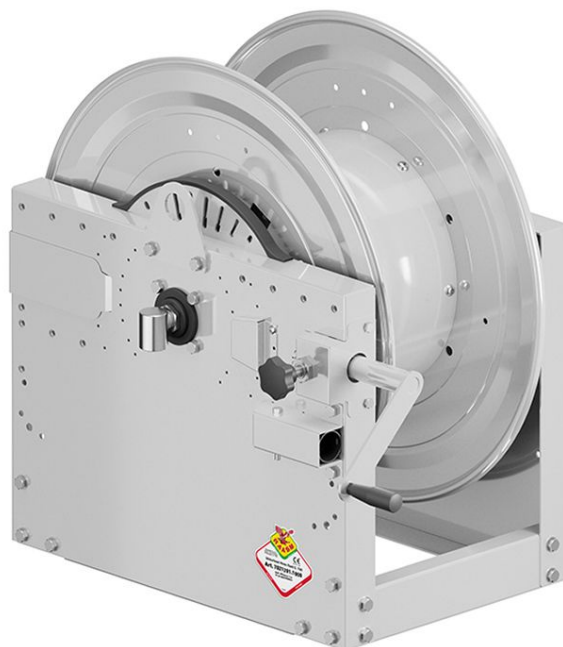

### OVERALL DIMENSIONS (mm)

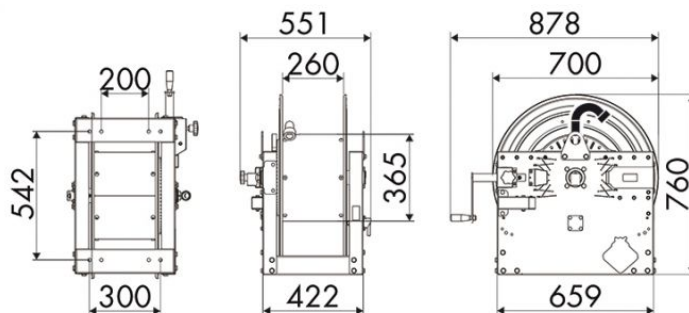

### HOSE REELS CAPACITY

∅ 3/8"	∅ 1/2"	∅ 3/4"	∅ 1"	∅ 1,1/4"	∅ 1,1/2"	∅ 2"
160 m	110 m	65 m	30 m	20 m	15 m	10 m