



## P/N 2A8/1677SS5

Diaphragm pump in polypropylene series PPB-12 with dual inlet/multi ported outlet, membranes and balls in Santoprene™ and seats in AISI 316 stainless steel and polypropylene

### AREAS OF USE

Aeronautics, Agriculture, Automotive, Building and road construction, Chemical industry, Manufacturing industry, Mining industry, Lube trucks and transports, Shipping and offshore, Railway transport

### FEATURES

Flow rate	65 l/min
Ratio	1:1
Max pressure	8 bar
Max cycles for minute	350 cpm
Delivery for cycles	0,188 l
Max suction lift	dry column 4,5 m - wet column 7,5 m
Max size pumpable solids	1,5 mm
Max working temperature	65 °C
Noise level	76 dB
Max air consumption	0,89 m3/min
Air working pressure	2 ÷ 6 bar
Air inlet connection	G 3/8" (f)
Air outlet connection (muffler)	G 3/4" (f)
Fluid inlet connection	dual inlet G 3/4" (f)
Fluid outlet connection	G 1/2" (f)
Balls for inlet	cylindrical ball valve



### OVERALL DIMENSIONS (mm)

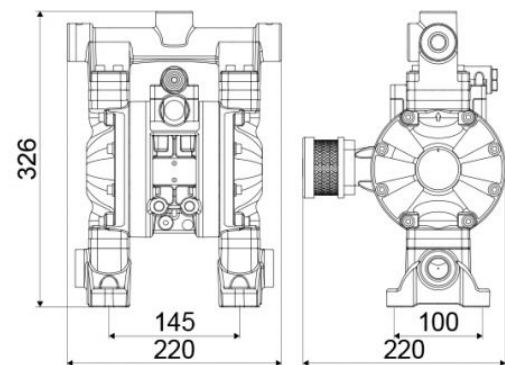

Membranes	Santoprene™
Balls	Santoprene™
Seats	polypropylene and AISI 316 stainless steel
Packing	No. 1 - 0,02 m3
Gross weight	5,8 kg