



ADVANCED FLUID  
MANAGEMENT SOLUTIONS

**RAASM S.p.a.**

Via Marangoni 33, 36022  
S. Zeno di Cassola (VI) Italy  
Tel. +39 0424 570891  
info@raasm.com

## P/N 2A4/2677NHI

Diaphragm pump in polypropylene series PPB-1 with 1" flanges, membranes in NBR, balls in Hytrel® and seats in AISI 316 stainless steel

### AREAS OF USE

Aeronautics, Agriculture, Automotive, Building and road construction, Chemical industry, Manufacturing industry, Mining industry, Lube trucks and transports, Shipping and offshore, Railway transport

### FEATURES

Flow rate	145 l/min
Ratio	1:1
Max pressure	8 bar
Max cycles for minute	270 cpm
Delivery for cycles	0,540 l
Max suction lift	dry column 5 m - wet column 7,5 m
Max size pumpable solids	3 mm
Max working temperature	65 °C
Noise level	78 dB
Max air consumption	1,1 m3/min
Air working pressure	2 ÷ 6 bar
Air inlet connection	G 3/8" (f)
Air outlet connection (muffler)	G 3/4" (f)
Fluid inlet connection	ANSI 150 - DIN PN 10 - JIS 10K 1" (25 mm) proneness to G 1.1/4" (f) thread



### OVERALL DIMENSIONS (mm)

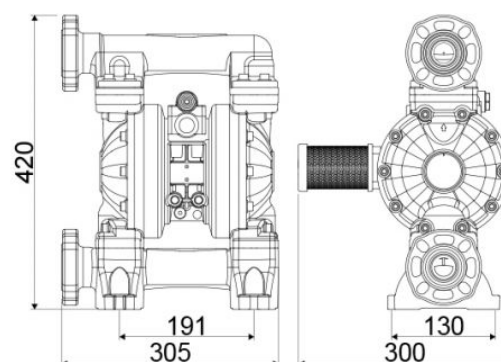

Fluid outlet connection	ANSI 150 - DIN PN 10 - JIS 10K 1" (25 mm) proneness to G 1.1/4" (f) thread
Balls for inlet	ball valve
Membranes	NBR
Balls	Hytrel®
Seats	AISI 316 stainless steel
Packing	No. 1 - 0,03 m3
Gross weight	9,6 kg