



ADVANCED FLUID
MANAGEMENT SOLUTIONS

RAASM S.p.a.

Via Marangoni 33, 36022
S. Zeno di Cassola (VI) Italy
Tel. +39 0424 570891
info@raasm.com

P/N 3C3/26111EAA



Diaphragm pump in aluminum series AAB-1-9 with multi ported inlet/outlet, membranes in EPDM, balls and seats in acetal

AREAS OF USE

Aeronautics, Agriculture, Automotive, Building and road construction, Chemical industry, Manufacturing industry, Mining industry, Lube trucks and transports, Shipping and offshore, Railway transport

FEATURES

Flow rate	170 l/min
Ratio	1:1
Max pressure	8 bar
Max cycles for minute	300 cpm
Delivery for cycles	0,590 l
Max suction lift	dry column 5 m - wet column 7,5 m
Max size pumpable solids	3 mm
Max working temperature	100 °C
Noise level	75 dB
Max air consumption	1,40 m3/min
Air working pressure	2 ÷ 6 bar
Air inlet connection	G 3/8" (f)
Air outlet connection (muffler)	G 1/2" (f)
Fluid inlet connection	4 x G 1" (f)
Fluid outlet connection	5 x G 1" (f)
Balls for inlet	ball valve
Membranes	EPDM



OVERALL DIMENSIONS (mm)

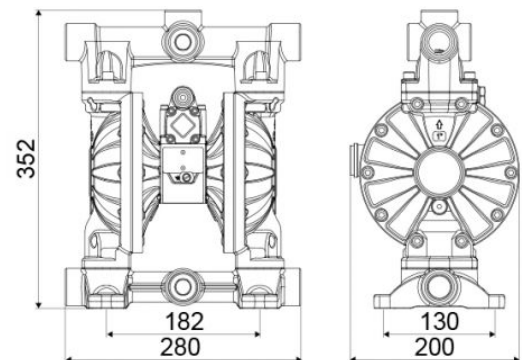

Balls	acetal
Seats	acetal
Packing	No. 1 - 0,03 m3
Gross weight	13 kg