



P/N 3C6/50111TTP

Diaphragm pump in aluminum series AABM-2 modular with 2" flanges, membranes and balls in Teflon® and seats in polypropylene

AREAS OF USE

Aeronautics, Agriculture, Automotive, Building and road construction, Chemical industry, Manufacturing industry, Mining industry, Lube trucks and transports, Shipping and offshore, Railway transport

FEATURES

Flow rate	550 l/min
Ratio	1:1
Max pressure	8 bar
Max cycles for minute	147 cpm
Delivery for cycles	3,950 l
Max suction lift	dry column 5 m - wet column 7,5 m
Max size pumpable solids	6,5 mm
Max working temperature	65 °C
Noise level	82 dB
Max air consumption	4,00 m3/min
Air working pressure	2 ÷ 6 bar
Air inlet connection	G 3/4" (f)
Air outlet connection (muffler)	G 1" (f)
Fluid inlet connection	ANSI 150 - DIN PN 10 - JIS 10K 2" (50 mm)
Fluid outlet connection	ANSI 150 - DIN PN 10 - JIS 10K 2" (50 mm)



OVERALL DIMENSIONS (mm)

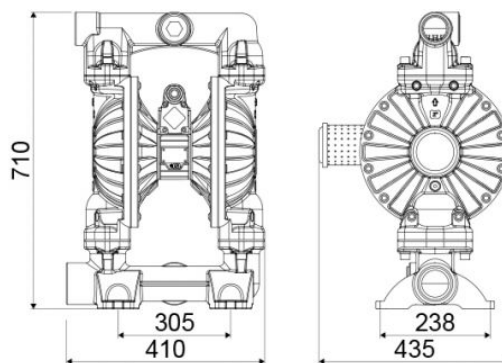

Balls for inlet	ball valve
Membranes	PTFE+Hytrel®
Balls	PTFE
Seats	polypropylene
Packing	No. 1 - 0,13 m3
Gross weight	50 kg