



P/N 3C3/50111TTP

Diaphragm pump in aluminum series AAB-2 with multi ported inlet/outlet, membranes and balls in Teflon® and seats in polypropylene

AREAS OF USE

Aeronautics, Agriculture, Automotive, Building and road construction, Chemical industry, Manufacturing industry, Mining industry, Lube trucks and transports, Shipping and offshore, Railway transport

FEATURES

Flow rate	570 l/min
Ratio	1:1
Max pressure	8 bar
Max cycles for minute	147 cpm
Delivery for cycles	4,150 l
Max suction lift	dry column 5 m - wet column 7,5 m
Max size pumpable solids	6,5 mm
Max working temperature	100 °C
Noise level	82 dB
Max air consumption	4,00 m3/min
Air working pressure	2 ÷ 6 bar
Air inlet connection	G 3/4" (f)
Air outlet connection (muffler)	G 1" (f)
Fluid inlet connection	G 2.1/2" (f)
Fluid outlet connection	G 2" (f)
Balls for inlet	ball valve
Membranes	PTFE+Hytrel®



OVERALL DIMENSIONS (mm)

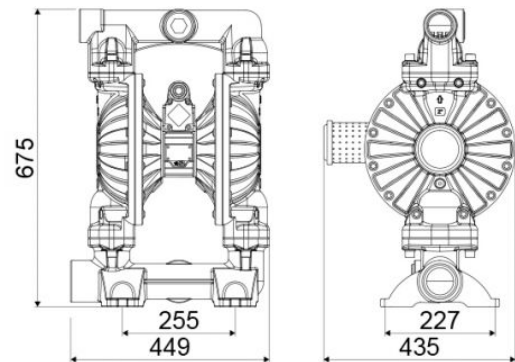

Balls	PTFE
Seats	polypropylene
Packing	No. 1 - 0,12 m3
Gross weight	45 kg