



ADVANCED FLUID
MANAGEMENT SOLUTIONS

RAASM S.p.a.

Via Marangoni 33, 36022
S. Zeno di Cassola (VI) Italy
Tel. +39 0424 570891
info@raasm.com

P/N 3C1/16111HHH



Diaphragm pump in aluminum series AAB-12 with membranes, balls and seats in Hytrel®

AREAS OF USE

Aeronautics, Agriculture, Automotive, Building and road construction, Chemical industry, Lube trucks and transports, Shipping and offshore, Railway transport

FEATURES

Flow rate	70 l/min
Ratio	1:1
Max pressure	8 bar
Max cycles for minute	400 cpm
Delivery for cycles	0,188 l
Max suction lift	dry column 4,5 m - wet column 7,5 m
Max size pumpable solids	1,5 mm
Max working temperature	100 °C
Noise level	75 dB
Max air consumption	0,80 m3/min
Air working pressure	2 ÷ 6 bar
Air inlet connection	G 3/8" (f)
Air outlet connection (muffler)	G 1/2" (f)
Fluid inlet connection	G 3/4" (f)
Fluid outlet connection	G 1/2" (f)
Balls for inlet	ball valve
Membranes	Hytrel®
Balls	Hytrel®



OVERALL DIMENSIONS (mm)

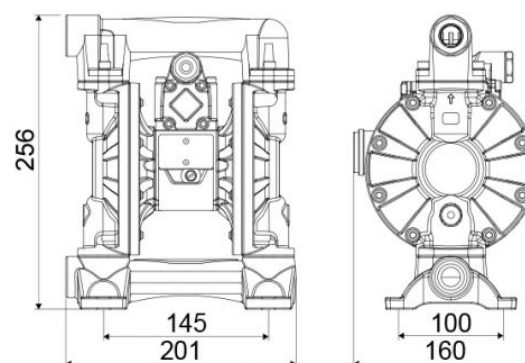

Seats	Hytrel®
Packing	No. 1 - 0,02 m3
Gross weight	6,3 kg