



ADVANCED FLUID
MANAGEMENT SOLUTIONS

RAASM S.p.a.

Via Marangoni 33, 36022
S. Zeno di Cassola (VI) Italy
Tel. +39 0424 570891
info@raasm.com

P/N 3C1/40111EAA



Diaphragm pump in aluminum series AAB-112 with membranes in EPDM, balls and seats in acetal

AREAS OF USE

Aeronautics, Agriculture, Automotive, Building and road construction, Chemical industry, Manufacturing industry, Mining industry, Lube trucks and transports, Shipping and offshore, Railway transport

FEATURES

Flow rate	480 l/min
Ratio	1:1
Max pressure	8 bar
Max cycles for minute	220 cpm
Delivery for cycles	2,150 l
Max suction lift	dry column 5 m - wet column 7,5 m
Max size pumpable solids	5,5 mm
Max working temperature	100 °C
Noise level	78 dB
Max air consumption	3,40 m ³ /min
Air working pressure	2 ÷ 6 bar
Air inlet connection	G 3/4" (f)
Air outlet connection (muffler)	G 1" (f)
Fluid inlet connection	G 2" (f)
Fluid outlet connection	G 1.1/2" (f)
Balls for inlet	ball valve
Membranes	EPDM
Balls	acetal



OVERALL DIMENSIONS (mm)

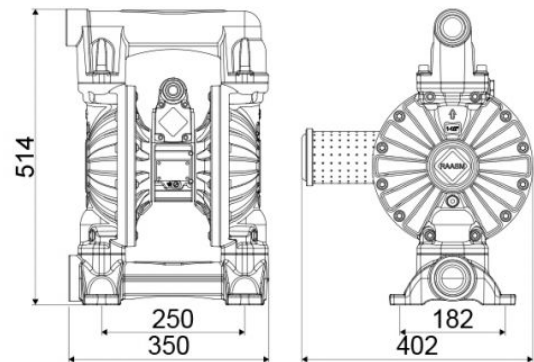

Seats	acetal
Packing	No. 1 - 0,07 m ³
Gross weight	21,5 kg