



ADVANCED FLUID
MANAGEMENT SOLUTIONS

RAASM S.p.a.

Via Marangoni 33, 36022
S. Zeno di Cassola (VI) Italy
Tel. +39 0424 570891
info@raasm.com

P/N 3C1/2666VNHH

Diaphragm pump in aluminum with cataphoresis treatment series AAB-1 with membranes in NBR, balls and seats in Hytrel®

AREAS OF USE

Aeronautics, Agriculture, Automotive, Building and road construction, Chemical industry, Lube trucks and transports, Shipping and offshore, Railway transport

FEATURES

Flow rate	170 l/min
Ratio	1:1
Max pressure	8 bar
Max cycles for minute	300 cpm
Delivery for cycles	0,590 l
Max suction lift	dry column 5 m - wet column 7,5 m
Max size pumpable solids	3 mm
Max working temperature	100 °C
Noise level	75 dB
Max air consumption	1,40 m ³ /min
Air working pressure	2 ÷ 6 bar
Air inlet connection	G 3/8" (f)
Air outlet connection (muffler)	G 1/2" (f)
Fluid inlet connection	G 1.1/4" (f)
Fluid outlet connection	G 1" (f)
Balls for inlet	ball valve
Membranes	NBR



OVERALL DIMENSIONS (mm)

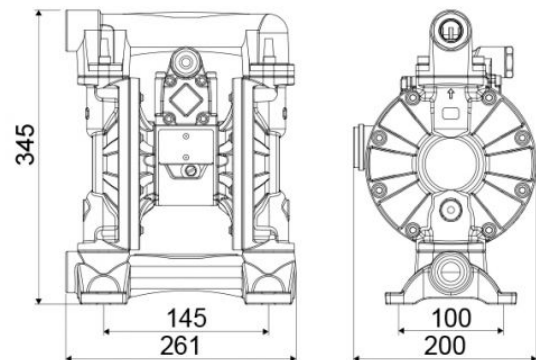

Balls	Hytrel®
Seats	Hytrel®
Packing	No. 1 - 0,03 m ³
Gross weight	12 kg