



ADVANCED FLUID  
MANAGEMENT SOLUTIONS

**RAASM S.p.a.**

Via Marangoni 33, 36022  
S. Zeno di Cassola (VI) Italy  
Tel. +39 0424 570891  
info@raasm.com

## P/N 2B8/16117NH52



Diaphragm pump in aluminum and polypropylene series APPB-12 with dual inlet/multi ported outlet, membranes in NBR, balls in Hytrel®, seats in AISI 316 stainless steel and polypropylene and ball valves with spring

### AREAS OF USE

Aeronautics, Agriculture, Automotive, Building and road construction, Chemical industry, Lube trucks and transports, Shipping and offshore, Railway transport

### FEATURES

Flow rate	60 l/min
Ratio	1:1
Compatible fluids	water, mineral-vegetable oils, diesel fuel
Motor and inside flanges material	aluminum
Wetted parts	polypropylene
Ball valve material	Hytrel®
Air inlet connection	G 3/8" (f)
Fluid inlet-outlet connection	dual inlet/multi-ported outlet G 3/4" (f) x G 1/2" (f)
Air working pressure	2 ÷ 6 bar
Max supply pressure	8 bar
Average air consumption	400 l/min
Noise level	75 dB
Fluid temperature	-10 ÷ +65 °C
Max solids diameter	ø 1,5 mm



### OVERALL DIMENSIONS (mm)

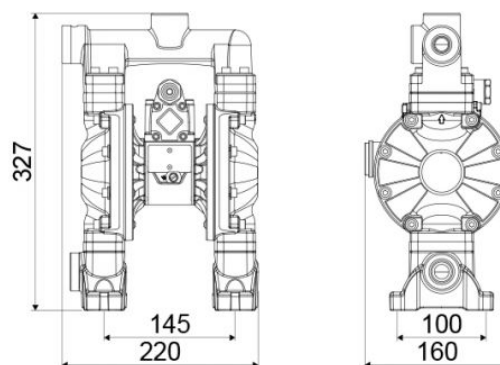

Suction-delivery ball valve with spring	cylindrical ball valve with spring
Packing	No. 1 - 0,015 m3
Weight	7 kg