



ADVANCED FLUID
MANAGEMENT SOLUTIONS

RAASM S.p.a.

Via Marangoni 33, 36022
S. Zeno di Cassola (VI) Italy
Tel. +39 0424 570891
info@raasm.com

P/N 2B8/16117HH5



Diaphragm pump in aluminum and polypropylene series APPB-12 with dual inlet/multi ported outlet, membranes and balls in Hytrel® and seats in AISI 316 stainless steel and polypropylene

AREAS OF USE

Aeronautics, Agriculture, Automotive, Building and road construction, Chemical industry, Lube trucks and transports, Shipping and offshore, Railway transport

FEATURES

Flow rate	60 l/min
Ratio	1:1
Max pressure	8 bar
Max cycles for minute	330 cpm
Delivery for cycles	0,188 l
Max suction lift	dry column 4,5 m - wet column 7,5 m
Max size pumpable solids	1,5 mm
Max working temperature	65 °C
Noise level	75 dB
Max air consumption	0,50 m3/min
Air working pressure	2 ÷ 6 bar
Air inlet connection	G 3/8" (f)
Air outlet connection (muffler)	G 1/2" (f)
Fluid inlet connection	dual inlet G 3/4" (f)
Fluid outlet connection	G 1/2" (f)
Balls for inlet	cylindrical ball valve



OVERALL DIMENSIONS (mm)

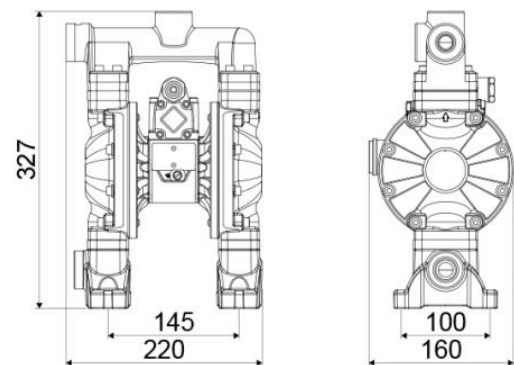

Membranes	Hytrel®
Balls	Hytrel®
Seats	polypropylene and AISI 316 stainless steel
Packing	No. 1 - 0,02 m3
Gross weight	5,7 kg