



ADVANCED FLUID
MANAGEMENT SOLUTIONS

RAASM S.p.a.

Via Marangoni 33, 36022
S. Zeno di Cassola (VI) Italy
Tel. +39 0424 570891
info@raasm.com

P/N 2B3/16117NH52



Diaphragm pump in aluminum and polypropylene series APPB-12 with multi ported inlet/outlet, membranes in NBR, balls in Hytrel®, seats in AISI 316 stainless steel and polypropylene and ball valves with spring

AREAS OF USE

Aeronautics, Agriculture, Automotive, Building and road construction, Chemical industry, Manufacturing industry, Lube trucks and transports, Shipping and offshore, Railway transport

FEATURES

Flow rate	60 l/min
Ratio	1:1
Compatible fluids	water, mineral-vegetable oils, diesel fuel
Motor and inside flanges material	aluminum
Wetted parts	polypropylene
Ball valve material	Hytrel®
Air inlet connection	G 3/8" (f)
Fluid inlet-outlet connection	G 3/4" (f) x G 1/2" (f)
Air working pressure	2 ÷ 6 bar
Max supply pressure	8 bar
Average air consumption	400 l/min
Noise level	75 dB
Fluid temperature	-10 ÷ +65 °C
Max solids diameter	ø 1,5 mm



OVERALL DIMENSIONS (mm)

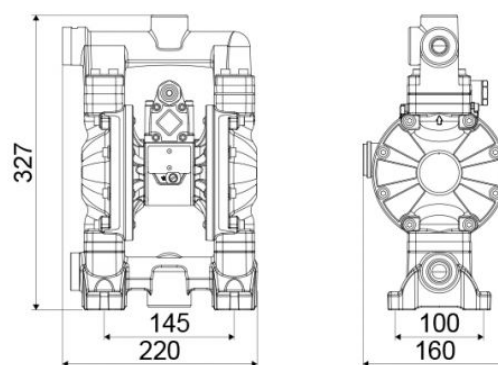

Suction-delivery ball valve with spring	cylindrical ball valve with spring
Packing	No. 1 - 0,015 m3
Weight	7,5 kg