



ADVANCED FLUID  
MANAGEMENT SOLUTIONS

**RAASM S.p.a.**

Via Marangoni 33, 36022  
S. Zeno di Cassola (VI) Italy  
Tel. +39 0424 570891  
info@raasm.com

## P/N 2B3/16117NH5



Diaphragm pump in aluminum and polypropylene series APPB-12 with multi ported inlet/outlet, membranes in NBR, balls in Hytrel® and seats in AISI 316 stainless steel and polypropylene

### AREAS OF USE

Aeronautics, Agriculture, Automotive, Building and road construction, Chemical industry, Manufacturing industry, Lube trucks and transports, Shipping and offshore, Railway transport

### FEATURES

Flow rate	60 l/min
Ratio	1:1
Max pressure	8 bar
Max cycles for minute	330 cpm
Delivery for cycles	0,188 l
Max suction lift	dry column 4,5 m - wet column 7,5 m
Max size pumpable solids	1,5 mm
Max working temperature	65 °C
Noise level	75 dB
Max air consumption	0,50 m <sup>3</sup> /min
Air working pressure	2 ÷ 6 bar
Air inlet connection	G 3/8" (f)
Air outlet connection (muffler)	G 1/2" (f)
Fluid inlet connection	G 3/4" (f) (G 1" (f) for drum)
Fluid outlet connection	G 1/2" (f)



### OVERALL DIMENSIONS (mm)

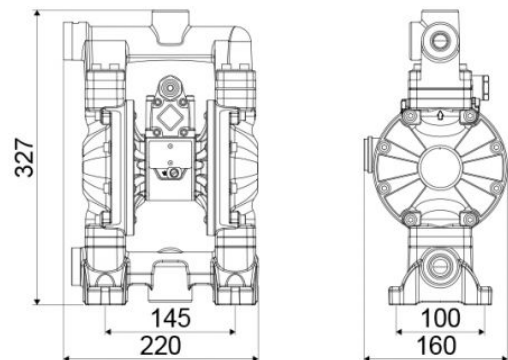

Balls for inlet	cylindrical ball valve
Membranes	NBR
Balls	Hytrel®
Seats	polypropylene and AISI 316 stainless steel
Packing	No. 1 - 0,02 m3
Gross weight	5,8 kg