



P/N 2B4/26117SSI

Diaphragm pump in aluminum and polypropylene series APPB-1 with 1" flanges, membranes and balls in Santoprene™ and seats in AISI 316 stainless steel

AREAS OF USE

Aeronautics, Agriculture, Automotive, Building and road construction, Chemical industry, Manufacturing industry, Lube trucks and transports, Shipping and offshore, Railway transport

FEATURES

Flow rate	170 l/min
Ratio	1:1
Max pressure	8 bar
Max cycles for minute	300 cpm
Delivery for cycles	0,590 l
Max suction lift	dry column 5 m - wet column 7,5 m
Max size pumpable solids	3 mm
Max working temperature	65 °C
Noise level	75 dB
Max air consumption	1,60 m3/min
Air working pressure	2 ÷ 6 bar
Air inlet connection	G 3/8" (f)
Air outlet connection (muffler)	G 1/2" (f)
Fluid inlet connection	ANSI 150 - DIN PN 10 - JIS 10K 1" (25 mm) proneness to G 1.1/4" (f) thread



OVERALL DIMENSIONS (mm)

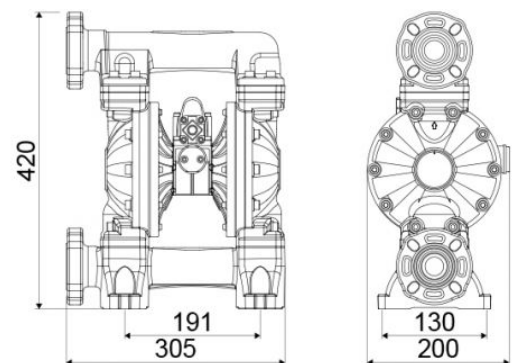

Fluid outlet connection	ANSI 150 - DIN PN 10 - JIS 10K 1" (25 mm) proneness to G 1.1/4" (f) thread
Balls for inlet	ball valve
Membranes	Santoprene™
Balls	Santoprene™
Seats	AISI 316 stainless steel
Packing	No. 1 - 0,03 m3
Gross weight	7 kg